

**THIS DOCUMENT NOT APPROVED  
FOR PRINTED DISTRIBUTION**

This Document May Be Viewed On-Line.

**T.O. 35C1-2-892-1**

---

**TECHNICAL MANUAL**

**OPERATION AND MAINTENANCE INSTRUCTIONS  
WITH ILLUSTRATED PARTS BREAKDOWN  
(ORGANIZATIONAL/INTERMEDIATE)**

**POWER SUPPLY,  
PP-7913/URC, P/N 10087-1000**

Harris Corporation, RF Communications Group  
F04606-82-D-0079

*Distribution Statement - This publication is required for official use or for administrative or operational purposes only. Distribution is limited to US Government agencies. Other requests for this document must be referred to Sacramento ALC/IMMEDTD, McClellan AFB, CA 95652-5609.*

Published under authority of the Secretary of the Air Force

---

**23 JULY 1985**

**LIST OF EFFECTIVE PAGES**

**INSERT LATEST CHANGED PAGES. DESTROY SUPERSEDED PAGES.**

NOTE: The portion of the text affected by the changes is indicated by a vertical line in the outer margins of the page. Changes to illustrations are indicated by miniature pointing hands. Changes to wiring diagrams are indicated by shaded areas.

Dates of issue for original and changed pages are:

Original...0... 23 Jul 85

**TOTAL NUMBER OF PAGES IN THIS PUBLICATION IS 52 CONSISTING OF THE FOLLOWING:**

Page No.	*Change No.	
Title.....	0	✓
A.....	0	✓
i-ix.....	0	✓
1-0 - 1-6.....	0	✓
2-1 - 2-8.....	0	✓
3-1 - 3-2.....	0	✓
4-1 - 4-3.....	0	✓
4-4 Blank.....	0	✓
5-1.....	0	✓
5-2 Blank.....	0	✓
6-1.....	0	✓
6-2 Blank.....	0	✓
7-1 - 7-6.....	0	✓
8-1.....	0	✓
8-2 Blank.....	0	✓
FP-1.....	0	✓
FP-2 Blank.....	0	✓

\*Zero in this column indicates an original page.

## SAFETY SUMMARY

The following are general safety precautions that are not related to any specific procedures and therefore do not appear elsewhere in this publication. These are recommended precautions that personnel must understand and apply during many phases of operation and maintenance.

### KEEP AWAY FROM LIVE CIRCUITS

Operating personnel must at all times observe all safety regulations. Do not replace components or make adjustments inside the equipment with the high voltage supply turned on. Under certain conditions, dangerous potentials may exist when the power control is in the off position, due to charges retained by capacitors. To avoid casualties, always remove power and discharge circuits to ground before touching any circuit components. Remove watches and rings before performing any maintenance procedures.

### DO NOT SERVICE OR ADJUST ALONE

Under no circumstances should any person reach into or enter the enclosure for the purpose of servicing or adjusting the equipment except in the presence of someone who is capable of rendering aid.

### RESUSCITATION

Personnel working with or near high voltages should be familiar with modern methods of resuscitation. Cardiopulmonary resuscitation procedures are outlined in T.O. 31-1-141-1, and annual refresher

training requirements are outlined in AFOSH STD 127-50.

The following warnings appear in the text in this volume, and are repeated here for emphasis.

#### WARNING

Improper grounding of the 1 KW LPA equipment can cause HIGH VOLTAGE dangerous to life to be present on the equipment chassis in the event of a malfunction.

#### WARNING

Always verify that primary power has been removed at the source before making any TBI terminal board wiring changes.

#### WARNING

This equipment contains voltages that can be dangerous to life.

### HANDLING OF ELECTROSTATIC DISCHARGE SENSITIVE DEVICES (ESDS)

Electrostatic Discharge Sensitive Devices (ESDS) must be handled with certain precautions that must be followed to minimize the effect of static build-up. Consult T.O. 00-25-234, DOD Std-1686, and DOD HDBK 263.

**TABLE OF CONTENTS**

<b>Section/Para</b>	<b>Page</b>
<b>CHAPTER 1. GENERAL INFORMATION</b>	
1-1. General Description and Purpose.....	1-1
1-2. Equipment Functional Description.....	1-1
1-3. Mechanical Design.....	1-1
1-4. Leading Particulators.....	1-1
1-5. Capabilities and Limitations.....	1-1
1-6. Equipment and Accessories Supplied.....	1-1
1-7. Equipment Required but not Supplied.....	1-1
1-8. Special Tools and Test Equipment.....	1-1
1-9. Related Publications.....	1-3
<b>CHAPTER 2. INSTALLATION</b>	
<b>I</b>	<b>INSTALLATION LOGISTICS</b>
2-1. Equipment Unpacking Procedure.....	2-1
2-2. Preparation for Installation.....	2-1
2-3. Site Considerations.....	2-1
<b>II</b>	<b>INSTALLATION PROCEDURE</b>
2-4. Installing the Equipment.....	2-6
2-5. 1KW Power Supply Mounting Instructions.....	2-6
2-5-1. 1KW Power Supply Stack Mounting Instructions.....	2-6
2-5-2. 1KW Power Supply Rack Mounting Instructions.....	2-6
2-6. Cabling Connections.....	2-6
2-7. Checking the Installation.....	2-7
<b>CHAPTER 3. PREPARATION FOR USE AND RESHIPMENT</b>	
<b>I</b>	<b>PREPARATION FOR USE</b>
3-1. Initial Control Settings.....	3-1
3-2. Initial Power Application.....	3-1
3-3. Step-By-Step Sequence for Initial Power Application.....	3-1
3-4. Initial Checkout.....	3-1
<b>II</b>	<b>PREPARATION FOR RESHIPMENT</b>
3-5. Preparation for Reshipment.....	3-2
3-6. Step-By-Step Disassembly Procedure.....	3-2
3-7. Step-By-Step Packing and Crating Procedure.....	3-2

## TABLE OF CONTENTS (Continued)

Section/Para		Page
CHAPTER 4. OPERATION		
I	CONTROLS AND INDICATORS	
	4-1. Introduction.....	4-1
	4-2. Indications of Normal Operation.....	4-2
II	OPERATING INSTRUCTIONS	
	4-3. Introduction.....	4-3
CHAPTER 5. THEORY OF OPERATION		
	5-1. General Description.....	5-1
	5-2. Primary Power Strapping.....	5-1
	5.3 Power On Control.....	5-1
	5.4 115 VAC Filament Supply.....	5-1
	5.5 13.5 VDC Supply.....	5-1
	5.6 High Voltage Supply.....	5-1
CHAPTER 6. MAINTENANCE		
	6-1. General.....	6-1
	6-2. Periodic Maintenance.....	6-1
CHAPTER 7. ILLUSTRATED PARTS BREAKDOWN		
I	INTRODUCTION	
	7-1. Purpose.....	7-1
	7-2. Scope.....	7-1
	7-3. Chapter Organization.....	7-1
	7-4. Source, Maintenance, and Recoverability (SMR) Codes.....	7-1
	7-5. Federal Supply Codes for Manufacturers (FSCM).....	7-1
II	MAINTENANCE PARTS LIST	

LIST OF ILLUSTRATIONS

Figure		Page
CHAPTER 1. GENERAL INFORMATION		
1-1	Power Supply PP-7913/URC .....	1-0
1-2	Mechanical Construction ..	1-2
CHAPTER 2. INSTALLATION		
2-1	Unpacking the Equipment .....	2-2
2-2	Rear Panel Detail and Strapping Instructions .....	2-2
2-3	Typical Stack Mount Detail .....	2-5
2-4	Dimensions .....	2-7
CHAPTER 4. OPERATION		
4-1	Operating Controls and Indicators .....	4-2
CHAPTER 7. ILLUSTRATED PARTS BREAKDOWN		
7-1	1 KW Power Supply, PP-7913/URC .....	7-1
CHAPTER 8. FOLDOUT DRAWINGS		
FO-1	1 KW Power Supply Schematic Diagram	

LIST OF TABLES

Table		Page
CHAPTER 1. GENERAL INFORMATION		
1-1	Leading Particulars .....	1-4
1-2	Capabilities and Limitations .....	1-5
1-3	Equipment and Accessories Supplied .....	1-5
1-4	Equipment Required but Not Supplied .....	1-5
1-5	Related Publications .....	1-6
CHAPTER 2. INSTALLATION		
2-1	Interconnection Cabling Information .....	2-8



**GLOSSARY**

A	Ampere(s)
A/D	Analog-to-Digital (Converter)
AFSK	Audio frequency shift keying; a baseband modulation scheme in which two audio frequencies are used to represent binary coded data; the frequency is shifted to one frequency to represent a 1 (mark) and to the other to represent a 0 (space).
AGC	Automatic gain control
ALE	Address latch enable
AM	Amplitude modulation; a modulation scheme in which the carrier is made to vary in amplitude in accordance with the modulating signal.
AME	Amplitude modulation equivalent
ANTIVOX	Prevents false VOX operation; see VOX
BFO	Beat Frequency Oscillator, used in SSB detection circuits
BIT	Built-in Test
BIU	Bus interface unit
BW	Bandwidth
CPU	Central processing unit
CREV	Converter reverse
CW	Continuous wave; a wave that does not vary in amplitude or frequency and is turned on and off to carry intelligence, e.g., Morse Code
D/A	Digital-to-Analog (Converter)
dB	Decibel(s)
dBm	Decibel(s) relative to one milliwatt
EMI	Electromagnetic interference
EPROM	Erasable programmable read-only memory
EU	Execution unit
HF	High frequency; a radio frequency band extending from about 3 MHz to 30 MHz; in this manual, HF includes 1.6 to 30 MHz.
HV	High voltage
IF	Intermediate frequency
IM	Intermodulation (distortion)
I/O	Input/Output
KREV	Keyer reverse
LCD	Liquid crystal display
LED	Light emitting diode
LPA	Linear power amplifier
LSB	Lower sideband; a modulation scheme in which the intelligence is carried on the first sideband below the carrier frequency; see SSB
MIC	Microphone
mA	Milliampere(s)
mV	Millivolt(s)
NBSV	Narrow band secure voice
PEP	Peak envelope power
PPC	Peak power control
PWB	Printed wiring board
RAM	Random access memory
rms	Root mean square
RTC	Real time clock
RX	Receive

## GLOSSARY (Continued)

S TONE	Sidetone
SSB	Single sideband; a modulation scheme in which the intelligence is carried by one of the carrier sidebands, the other sideband and the carrier center frequency being suppressed
TGC	Transmitter gain control
TX	Transmit
uA	Microampere(s)
uP	Microprocessor
USB	Upper sideband; a modulation scheme in which the intelligence is carried on the first sideband above the carrier frequency; see SSB
uV	Microvolt(s)
Vac	Volts, alternating current
VCO	Voltage controlled oscillator
Vdc	Volts, direct current
VOX	Voice operated transmission
VSWR	Voltage standing wave ratio; the ratio of the maximum to the minimum voltage of a standing wave on a radio frequency transmission line
W	Watt(s)

## **INTRODUCTION**

The purpose of this on-equipment level manual is to provide all information necessary for the installation, operation and on-equipment maintenance of Power Supply, PP-7913/URC, manufactured by the RF Communications Group of Harris Corporation, Rochester, New York. The manual is divided into eight chapters. The contents of each chapter are briefly described in the following paragraphs.

Chapter 1 provides a general description and a list of capabilities and limitations of the Power Supply, PP-7913/URC. A list of companion equipment references are included along with the components that form the PP-7913/URC.

Chapter 2 provides the information necessary for planning and carrying out the installation of the Power Supply, PP-7913/URC. A dimensional outline drawing is provided to show dimensions and other information required for proper installation.

Chapter 3 provides instructions for preparing the Power Supply, PP-7913/URC for use, including the initial application of power and checkout. Instructions for repacking the equipment for reshipment are also included in Chapter 3.

Chapter 4 provides complete operating instructions for the Power Supply, PP-7913/URC in all modes and contains a list of operating controls and indicators.

Chapter 5 provides a complete theory of operation for the Power Supply, PP-7913/URC. An overall theory and detailed theory of individual functional circuits are provided.

Chapter 6 describes the on-equipment location maintenance procedures. On-equipment location maintenance is based on the use of built-in test (BIT) features of the equipment to isolate problems to the replaceable subassembly or printed wiring board (PWB) level. Depot maintenance is supplied in a separate publication, T.O. 35C1-2-892-3. The Depot Manual is based on performance testing and trouble analysis of the subassembly or PWB to locate and replace faulty parts at the lowest replaceable unit level (LRU).

Chapter 7 contains the Illustrated Parts Breakdown (IPB) information at the on-equipment level. This includes assemblies and parts that may be replaced at the on-equipment location.

Chapter 8 contains all fold-out (FO) drawings. A cross reference list is provided as well as the individual drawings referenced throughout chapters 1 to 7. The diagrams are numbered FO-1, FO-2, etc. They are printed on sheets with page-size blank aprons to permit viewing the diagram with the rest of the book closed or opened to another page.

**APPLICABLE SPECIFICATIONS**

The following specifications, standards, and publications were used in the preparation of this manual.

<b>SPECIFICATION</b>	<b>NAME</b>
MIL-M-38798B, para. 3.4	Combined Operation and Maintenance Instructions Manual (Equipment).
MIL-M-38807, Amend. 4	Preparation of Illustrated Parts Breakdown.
MIL-M-38790 and MIL-M-38784A	General Requirements for Preparation of Technical Manuals.

**APPLICABLE STANDARDS**

<b>STANDARD</b>	<b>NAME</b>
MIL-STD-12	Abbreviations for use on Drawings and in Technical Type Publications.
MIL-STD-15-1A	Graphic Symbols for Electrical Components.
MIL-STD-17-1	Mechanical Symbols.
MIL-STD-806	Graphic Symbols for Logic Diagrams.

**APPLICABLE PUBLICATIONS**

<b>PUBLICATION</b>	<b>NAME</b>
DOD 5200.20	Distribution Statements on Technical Documents.
USAS Y14.15-1966	Electrical and Electronic Diagrams.
USAS Y32.16-1968	Electrical and Electronic Reference Designations.
T.O. 31-1-141 (Series)	Technical Manual-Basic Electronic Technology and Testing Practices.

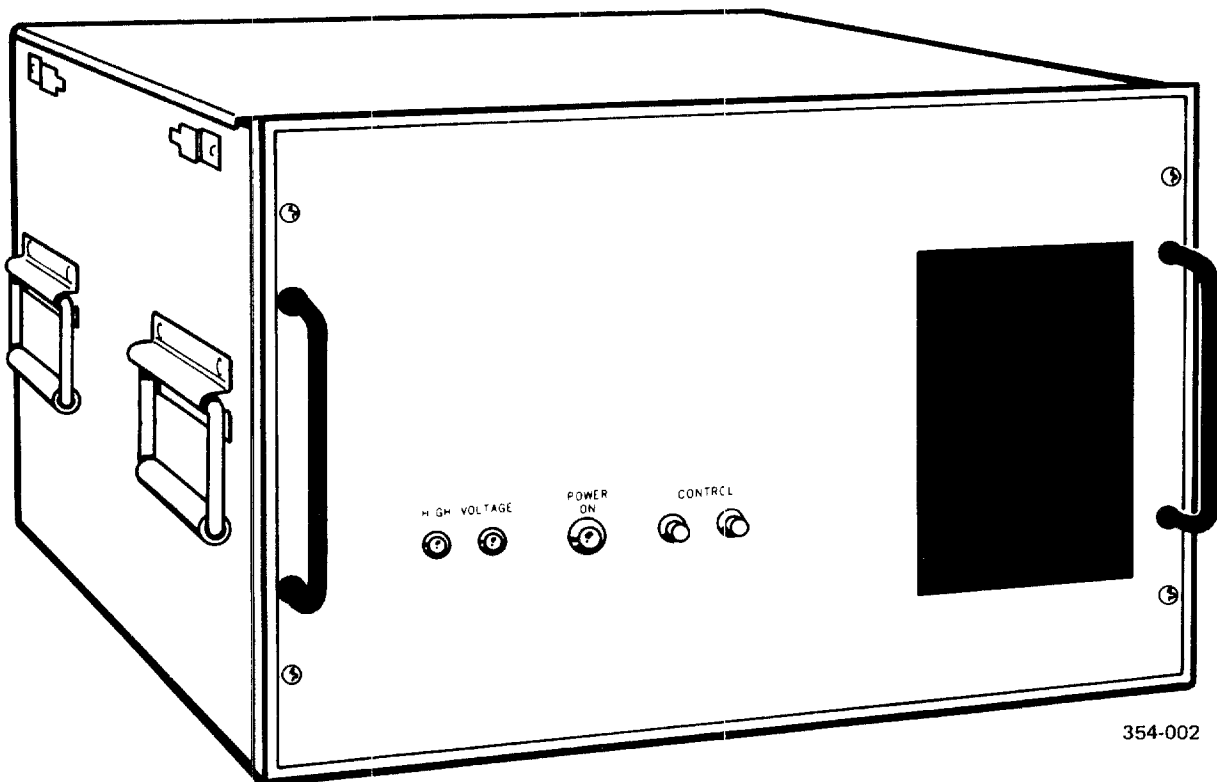

Figure 1-1. Power Supply PP-7913/URC

## CHAPTER 1

## GENERAL INFORMATION

**1-1. GENERAL DESCRIPTION AND PURPOSE.** Power Supply PP-7913/URC, shown in figure 1-1, and hereafter known as the 1KW Power Supply, is a 115/208/230 Vac, 10%, single-phase 50/60/400 Hz power supply that produces three output voltages: +3000 Vdc at 1A, +13.5 Vdc at 8A, and 115 Vac at 1A.

a. Applications. The 1KW Power Supply is rated for continuous duty applications where the load requirement is to satisfy the demands of a 1KW Linear Power Amplifier rated for 1KW peak and average output power.

b. Reliability. The 1KW Power Supply is designed for continuous operation under the most severe environmental conditions. It is intended for fixed station applications.

c. Test Features. The 1KW Power Supply provides analog outputs for use in metering and built-in-test (BIT) evaluation.

d. Power Requirements. Primary power requirements are for 115 Vac @ 40 amperes maximum, or 208/230 Vac @ 20/18 amperes maximum. The primary power frequency can be 50, 60, or 400 Hz. The primary power source should be capable of delivering 4000 volt-amperes..

## 1-2. EQUIPMENT FUNCTIONAL DESCRIPTION.

a. +13.5 VDC Section. The +13.5 Vdc power supply section uses a full-wave rectifier at the output of a LV power transformer to produce this general purpose output. The primary of the transformer can be strapped for proper primary voltage at a terminal board accessible at the rear panel. Both sides of the transformer primary are protected by circuit breakers. Primary voltage to the LV Power Supply is controlled by the application of +13.5 Vdc from an external source, through two interlocks on the Power Supply, to the LV power-on relay.

b. HV Supply Section. The HV power supply section uses a full-wave bridge rectifier to produce a single +3000 Vdc output. The primary of the HV transformer can be strapped for either 115 Vac, 208 Vac, or 230 Vac. The transformer and the HV output circuit are protected by circuit breakers in each side of the line. The HV supply is controlled by the HV ON control line which furnishes a control ground to the HV contactor.

c. 115 Vac Section. 115 Vac is made available directly from the strapped primary side of the LV power transformer as tube filament power for the 1 KW LPA.

**1-3. MECHANICAL DESIGN.** The mechanical construction of the 1KW Power Supply is shown in figure 1-2.

**1-4. LEADING PARTICULARS.** The characteristics of the 1KW Power Supply are summarized in table 1-1. This table includes physical data and operating/storage environment data.

**1-5. CAPABILITIES AND LIMITATIONS.** The capabilities and limitations of the 1KW Power Supply are described in table 1-2. For interconnection information, see table 2-1.

**1-6. EQUIPMENT AND ACCESSORIES SUPPLIED.** Table 1-3 lists the assemblies, components, units, cables, and accessory kits supplied with the 1 KW Power Supply.

**1-7. EQUIPMENT REQUIRED BUT NOT SUPPLIED.** Table 1-4 lists equipment required, but not supplied, for the installation and operation of the 1 KW Power Supply. It is specifically designed to interface with the equipment listed in table 1-4.

**1-8. SPECIAL TOOLS AND TEST EQUIPMENT.** The servicing and maintenance of the 1 KW Power Supply do not require any special tools, test jigs, or fixtures. There are no adjustments in the 1 KW Power Supply. Field maintenance for the 1KW Power Supply is limited to replacing the

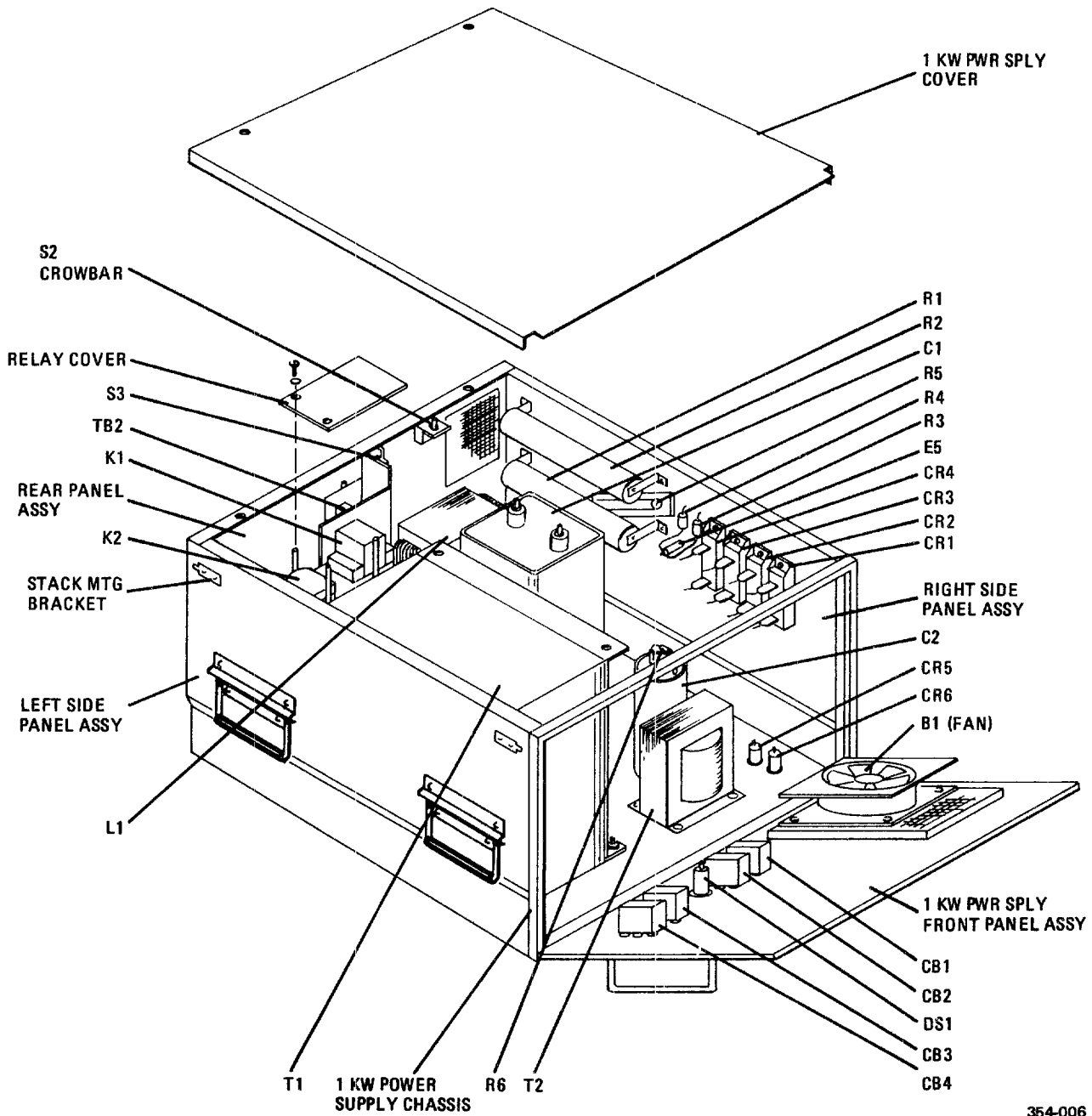

354-006

Figure 1-2. Mechanical Construction

components identified in Chapter 7, Illustrated Parts Breakdown. Refer to the Depot Manual for a list of test equipment used to service this equipment at the Depot level

**1-9. RELATED PUBLICATIONS.** Table 1-5 lists the Technical Order publications related to use of the 1 KW Power Supply.



**Table 1-1. Leading Particulars**

Item	Characteristic or Value
Dimensions: Height: Width: Depth: Weight:	10.5 inches (26.6 cm) 16.8 inches (42.5 cm) 18.8 inches (47.7 cm) 135 pounds (9.1 kg)
Power Requirements	115/208/230 Vac @ 4/20/8 Amps (maximum)
Operating Environment	-30 to +50 degrees C
Storage Environment	-60 to +60 degrees C 99% Humidity
Operating Altitude	10,000 feet
Transport Altitude	40,000 Feet
Shock/Vibration	MIL-STD-810C
Cooling	Convection and forced air (built-in fan)
Cabling Requirements	Power and control
Transportability	Manual Methods Apply
Set-up Time	Less than 1 hour

**Table 1-2. Capabilities and Limitations**

Description of Characteristic																	
Primary Power	115, 208, or 230 Vac, 10%, single phase, 50-400 Hz																
Remote Capability	6 feet (1.83 M) separation (typical) between 1 KW Power Supply and 1 KW LPA																
Control Lines: (J1)	<table> <tr> <td>PWR ON:</td> <td>+13.5 Vdc</td> </tr> <tr> <td>H.V. ON:</td> <td>GND</td> </tr> <tr> <td>Filament:</td> <td>115 Vac</td> </tr> <tr> <td>Filament:</td> <td>115 Vac</td> </tr> <tr> <td>PWR ON Ret:</td> <td>GND</td> </tr> <tr> <td>+13.5 Vdc:</td> <td>+13.5 Vdc</td> </tr> <tr> <td>B+ Sample:</td> <td>0 - +30 Vdc</td> </tr> <tr> <td>+3000 Vdc:</td> <td>+3000 Vdc</td> </tr> </table>	PWR ON:	+13.5 Vdc	H.V. ON:	GND	Filament:	115 Vac	Filament:	115 Vac	PWR ON Ret:	GND	+13.5 Vdc:	+13.5 Vdc	B+ Sample:	0 - +30 Vdc	+3000 Vdc:	+3000 Vdc
PWR ON:	+13.5 Vdc																
H.V. ON:	GND																
Filament:	115 Vac																
Filament:	115 Vac																
PWR ON Ret:	GND																
+13.5 Vdc:	+13.5 Vdc																
B+ Sample:	0 - +30 Vdc																
+3000 Vdc:	+3000 Vdc																

**Table 1-3. Equipment and Accessories Supplied**

Qty	Item	Use
1	Power Supply PP-7913/URC	Provides the operating voltages to the 1 KW LPA

**Table 1-4. Equipment Required but Not Supplied**

Qty	Item	Description
1	100 Watt Transceiver RT-1446/URC	Companion equipment used for reception and transmission of RF signals.
1	1 KW LPA AM-7224/URC	Companion equipment that amplifies 100 Watt Transceiver output to 1 KW level.
1	Coupler, Antenna AN/URA-38( )	Companion equipment used to match the 1 KW LPA to the antenna system.
1 drop per screw	Loctite #242 (Blue)	Used to hold handles to front panel.

Table 1-5. Related Publications

Title	Publication No.
100/500 Watt Antenna Coupler, CU-2310/URC On-Equipment Manual Depot Manual Work Cards	T.O. 31R2-2URC-111 T.O. 31R2-2URC-113 T.O. 31R2-2URC-116WC-1
Receiver-Transmitter, Radio, RT-1446/URC On-Equipment Manual Depot Manual Work Cards	T.O. 31R2-2URC-81 T.O. 31R2-2URC-83 T.O. 31R2-2URC-86WC-1
Amplifier, Radio Frequency, AM-7223/URC On-Equipment Manual Depot Manual Work Cards	T.O. 31R2-2URC-101 T.O. 31R2-2URC-103 T.O. 31R2-2URC-106WC-1
Power Supply, PP-7913/URC On-Equipment Manual Depot Manual Work Cards	T.O. 35C1-2-892-1 T.O. 35C1-2-892-3 T.O. 35C1-2-892-6WC-1
Amplifier, Radio Frequency, AM-7224/URC On-Equipment Manual Depot Manual Work Cards	T.O. 31R2-2URC-121 T.O. 31R2-2URC-123 T.O. 35C1-2-892-6WC-1
Remote Control Unit, C-11329/URC On-Equipment Manual Depot Manual Work Cards	T.O. 31R2-2URC-91 T.O. 31R2-2URC-93 T.O. 31R2-2URC-96WC-1
Overall System Work Cards	T.O. 31R2-2URC-126WC-1

## CHAPTER 2

### INSTALLATION

---

**WARNING**

Dangerous voltages exist in this radio equipment. Before removing any covers, disconnect primary power.

#### Section I. INSTALLATION LOGISTICS

**2-1. EQUIPMENT UNPACKING PROCEDURE.** The 1KW Power Supply is packed in a corrugated cardboard box for shipment. A two-piece foam enclosure protects the equipment from rough handling.

- a. When the unit is received, carefully inspect the exterior of the box. Look for any damage, signs of rough handling or weather exposure (e.g., water damage) or signs that the box may have been tampered with. If any of these conditions are present, carefully note and report them to the proper authority (refer to T.O. 00-35D-54). An external sticker on the shipping box provides additional instructions concerning inspection of the package.
- b. Refer to figure 2-1 for instructions concerning unpacking the box. The box consists of double-walled cardboard with reinforced strapping tape. The tool required to open the box is a sharp knife. Use the knife carefully to avoid injury when opening the box. Keep the packing box in a secure place for possible future use.
- c. After removing the equipment from the box, use the packing list in the ancillary package to verify the presence of each item in the shipment. Any shortages of items should be reported to the proper authority (refer to T.O. 00-35D-54).
- d. The boxed equipment weighs a total of 145 pounds (65.7 Kg). Use normal care to move the boxed equipment into the general location where it is to be installed. Once unpacked, the 1KW Power Supply weighs a total of 135 pounds and may be handled by two individuals.

**2-2. PREPARATION FOR INSTALLATION.** Site selection is the most important consideration in preparing for installation of the equipment. Details for site selection will vary depending on the use of the 1KW Power Supply.

**2-3. SITE CONSIDERATIONS.** A number of factors should be considered, from security to operational requirements, and it is the responsibility of the user to determine which has precedence. Each of the following items should be considered in site selection:

a. Power Source. Power requirements are identified in table 1-1 (see chapter 1 of this manual). Figure 2-2 shows rear panel detail and gives power supply strapping instructions. Consideration must be given to the type and size of power cable used to allow for the voltage and current that is required (table 1-1).

b. Loading. Depending on the installation method, be sure the selected space has adequate strength to support the weight of the equipment.

c. Accessibility. Consider the space needed for access to the equipment for servicing, operating, maintenance, etc.

d. 1KW LPA. Location of the 1KW Power Supply should take into account the location of the 1KW LPA. Avoid long cable runs (6 feet is typical).

e. System Ground. Make sure the system is properly grounded for safety (e.g., lightning hazard) (refer to T.O. 31-10-24).

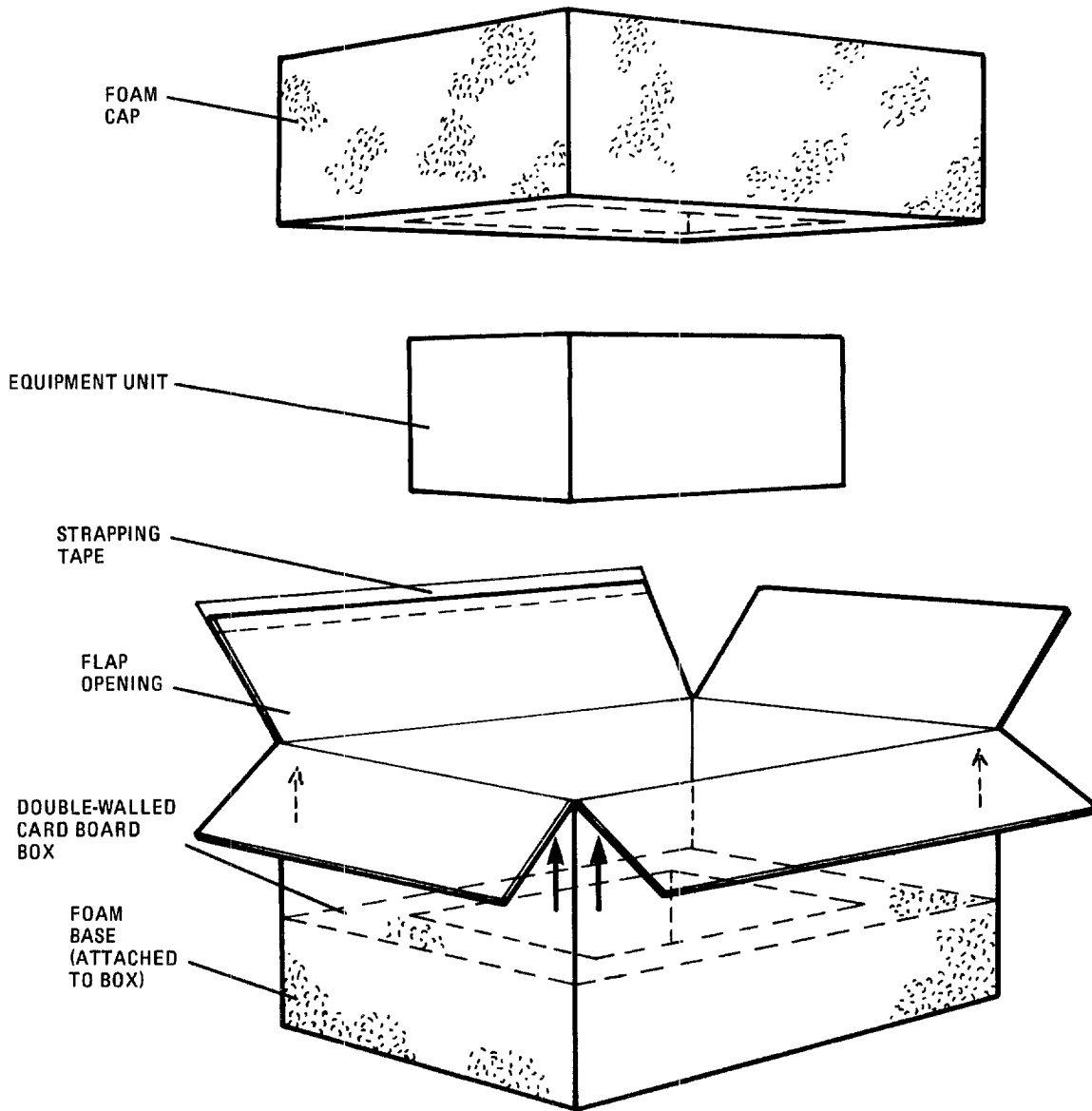

UNPACKING PROCEDURE

1. PLACE BOX ON FLOOR WITH ARROWS MARKED ON EACH SIDE POINTING UP.
2. CUT TAPE ON TOP OF BOX AND REMOVE FOAM CAP FROM BOX.
3. LIFT EQUIPMENT UNIT OUT OF BOX.
4. SAVE BOX AND FOAM CAP FOR RESHIPMENT.

350-003

Figure 2-1. Unpacking the Equipment

**TB2 Primary Power Jumpering**

Nominal Voltage	Jumper 1	Jumper 2	Jumper 3	Jumper 4	#14 AWG Jumper
115 Vac	2 to 6	4 to 8	10 to 12	9 to 11	Connect to 2
208 Vac	4 to 7	(None)	10 to 13	(None)	Connect to 3
230 Vac	4 to 6	(None)	10 to 11	(None)	Connect to 2

**NOTES**

1. Numbers above refer to terminals on TB2.
2. Jumpers must be of #14 AWG wire minimum.
3. Do not complete jumper connections with primary power applied to TB1.

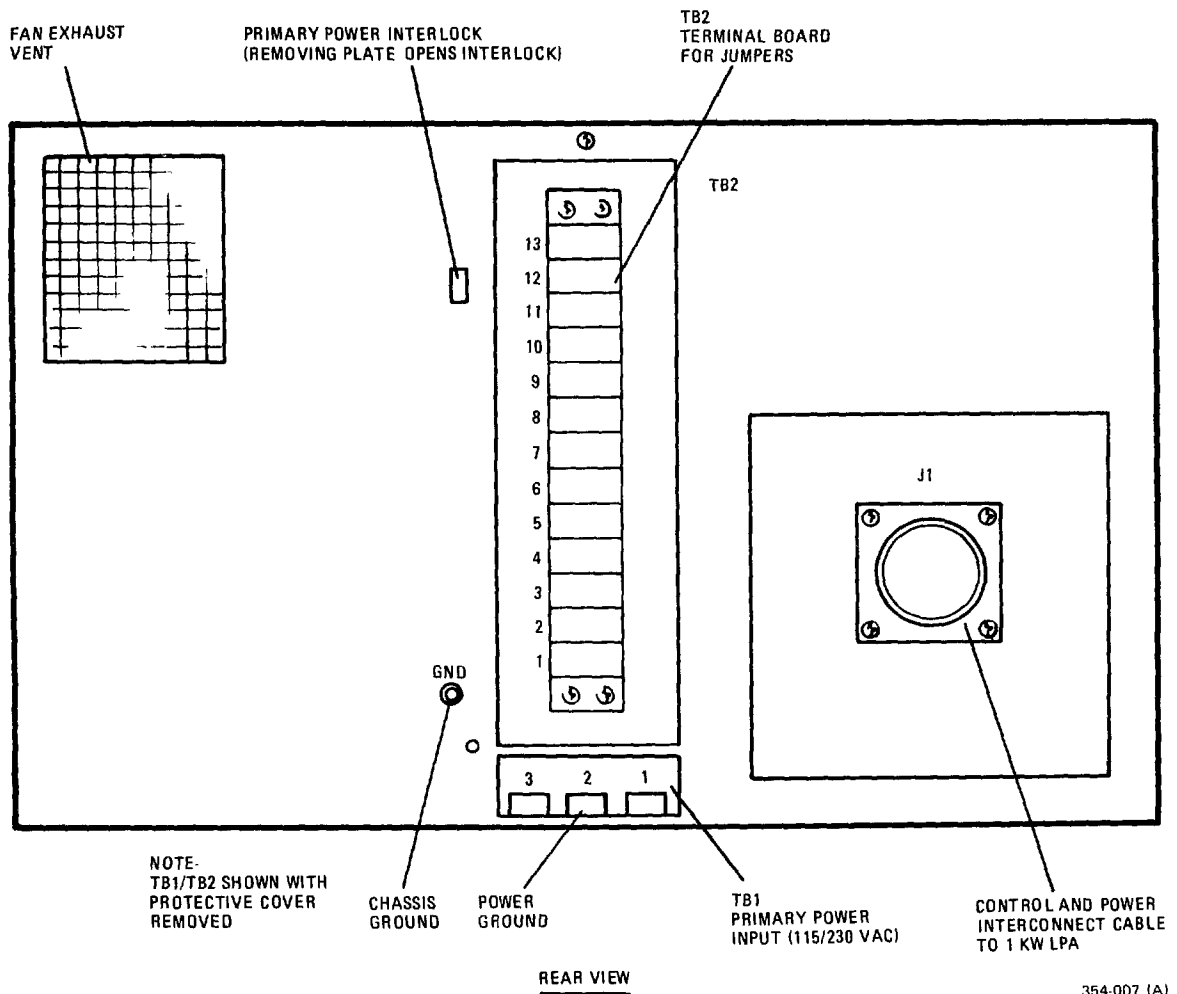

**Figure 2-2. Rear Panel Detail and Strapping Instructions**

f. Environment. The 1KW Power Supply will operate normally over an ambient temperature range of -30 to + 50 degrees C.

g. Interaction. The 1KW Power Supply should not interfere with or have interference problems with adjacent electronic equipment.

h. Heat Dissipation. Heat dissipation is not normally a problem with the 1KW Power Supply. Avoid positioning near other heat sources, and provide adequate ventilation.

i. Servicing. Allow for space to store any replacement assemblies, servicing tools, and test equipment.

j. Companion Equipment. Since the 1KW Power Supply is to be operated in conjunction with some of the companion equipment identified in table 1-4 (see chapter 1 of this manual), additional considerations may be required as identified in the companion equipment manuals.

k. Mounting. Once the site has been selected, the method of mounting the equipment should be considered. Each mounting method requires a particular type of mounting hardware. The mounting holes at the sides of the equipment can be used for slide mounts, brackets, posts, etc., depending on the manner of installation. Most installations of the equipment will result in one of the mounting techniques described in the following paragraphs.

l. Installation Configuration. The 1KW Power Supply interfaces with the 1KW LPA via the PA-PS control cable.

m. Grounding. Proper grounding of the 1KW Power Supply is recommended to prevent possible serious personnel hazards in the event of equipment malfunctions (refer to T.O. 31-10-24). Should be 10 ohms or less.



Improper grounding of the 1KW LPA equipment can cause HIGH VOLTAGE which is dangerous to life to be present on the equipment chassis in the event of a malfunction.

The ground straps should be constructed of wide copper material or braid, and should be as short as possible. Ground straps should be clamped and bonded to a cold water pipe or other metal conductor that provides a good ground.

n. Typical 1KW LPA Installation. A typical stack mount 1KW Power Supply installation is shown in figure 2-3.

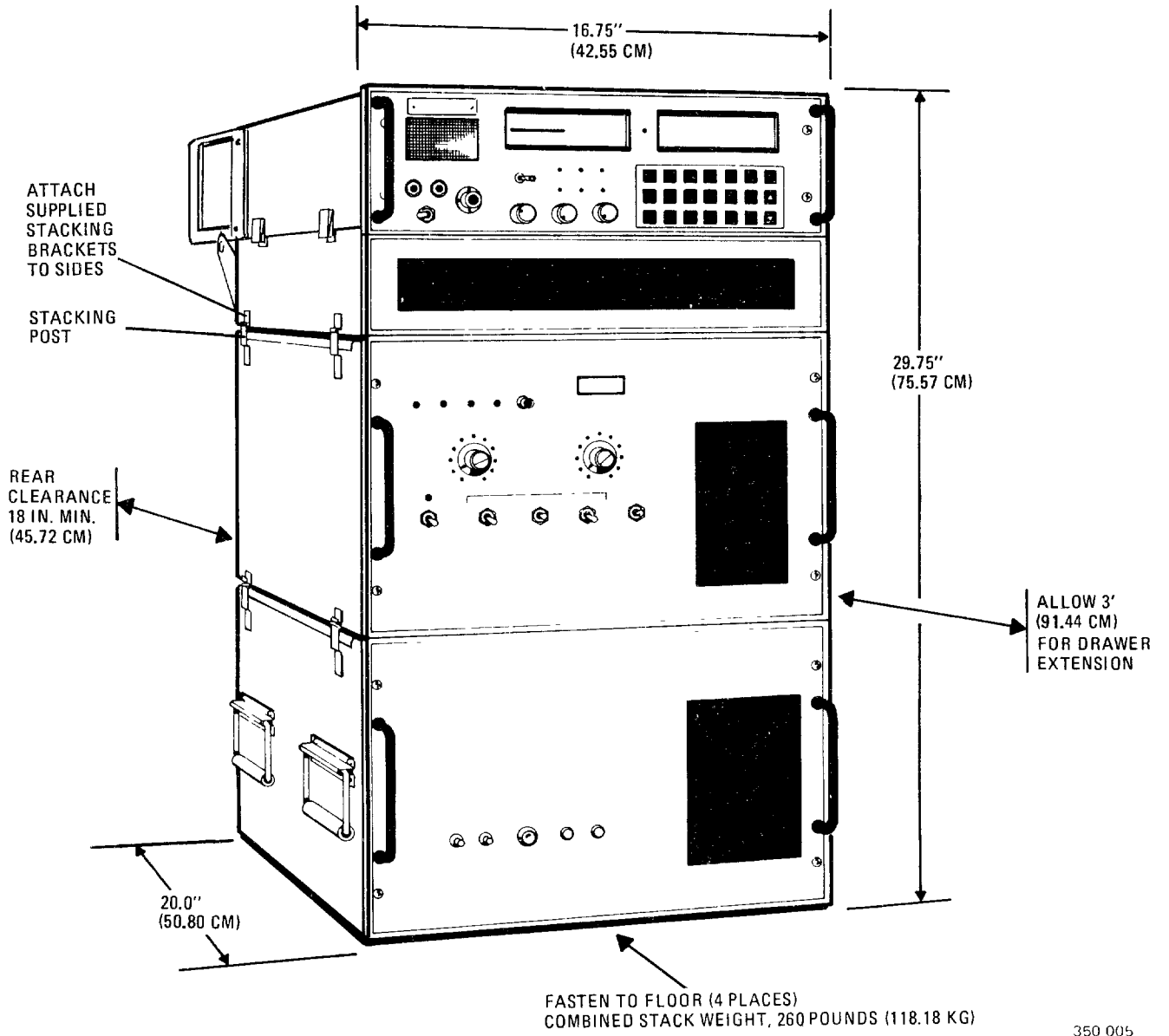

Figure 2-3. Typical Stack Mount Detail



## Section II. INSTALLATION PROCEDURE

**2-4. INSTALLING THE EQUIPMENT.** After unpacking the equipment and selecting the site, install the 1KW Power Supply as described in the following paragraphs.

a. Time Requirement. Installation should not take more than two hours.

b. Tool Requirements. Installation is accomplished with common hand tools, e.g., socket wrenches, screwdrivers, pliers, etc.

c. Personnel Requirements. Equipment positioning requires two individuals to lift and place the unit in position. Once the equipment is positioned and secured, one person can complete the installation in approximately 30 minutes.

**2-5. 1KW POWER SUPPLY MOUNTING INSTRUCTIONS.** The exact method of mounting the 1KW Power Supply depends upon the type of installation selected. Refer to figure 2-4 for 1KW Power Supply dimensions. Make sure that the mounting surface allows adequate room for the 1KW Power Supply and has proper clearance for cable interconnection.

**2-5-1. 1KW Power Supply Stack Mounting Instructions.**

- a. Refer to figure 2-4 for the 1KW Power Supply dimensions. Make sure that the mounting surface allows adequate room for ventilation intakes and outlets, and has proper clearance for cable interconnection.
- b. Install the stack mounting posts, using the hardware provided in the ancillary kit and the screw holes provided in the chassis of the 1KW Power Supply.
- c. Secure the 1KW Power Supply to the mounting surface, using appropriate hardware.

**2-5-2. 1KW Power Supply Rack Mounting Instructions.**

- a. Refer to figure 2-4 for the 1KW Power Supply dimensions. Make sure that the mounting surface allows adequate room for ventilation intakes and outlets, and has proper clearance for cable interconnection.

b. Install slide mounting brackets and slides, using the appropriate hardware.

c. Carefully lift the Power Supply and insert the slides in the mounting rack slide brackets. Ensure that the equipment is properly seated.

**2-6. CABLING CONNECTIONS.** After the equipment has been positioned and secured, fabricate and connect the 1KW Power Supply cables as described in the following paragraphs.

a. Interconnection and Interface. Standard cables should be used.

b. Cable Fabrication. Detailed information on cable fabrication is provided in table 2-1.

**CAUTION**

High voltage wire must be a separate shielded wire rated at 20 KV as shown in the fabrication procedure.

c. See figure 2-2 for primary power strapping information.

**2-7. CHECKING THE INSTALLATION.** After the 1KW Power Supply has been installed and interconnection cables are connected, verify that each item in the list below has been completed before applying power:

- a. All connectors are attached and tight.
- b. Ground wires are connected between the 1KW Power Supply and a known good ground. Examples of good grounds are a cold water pipe, a long copper stake pounded into solid earth, or a system ground bus at an existing site (refer to T.O. 31-10-24). A good ground is 10 ohms or less.
- c. Hardware for the equipment is securely tightened.
- d. Verify power supply primary power strapping according to figure 2-2.

After considering each item on the list above, the equipment may be considered ready for the application of power. Power application and initial equipment testing are discussed in chapter 3 of this manual.

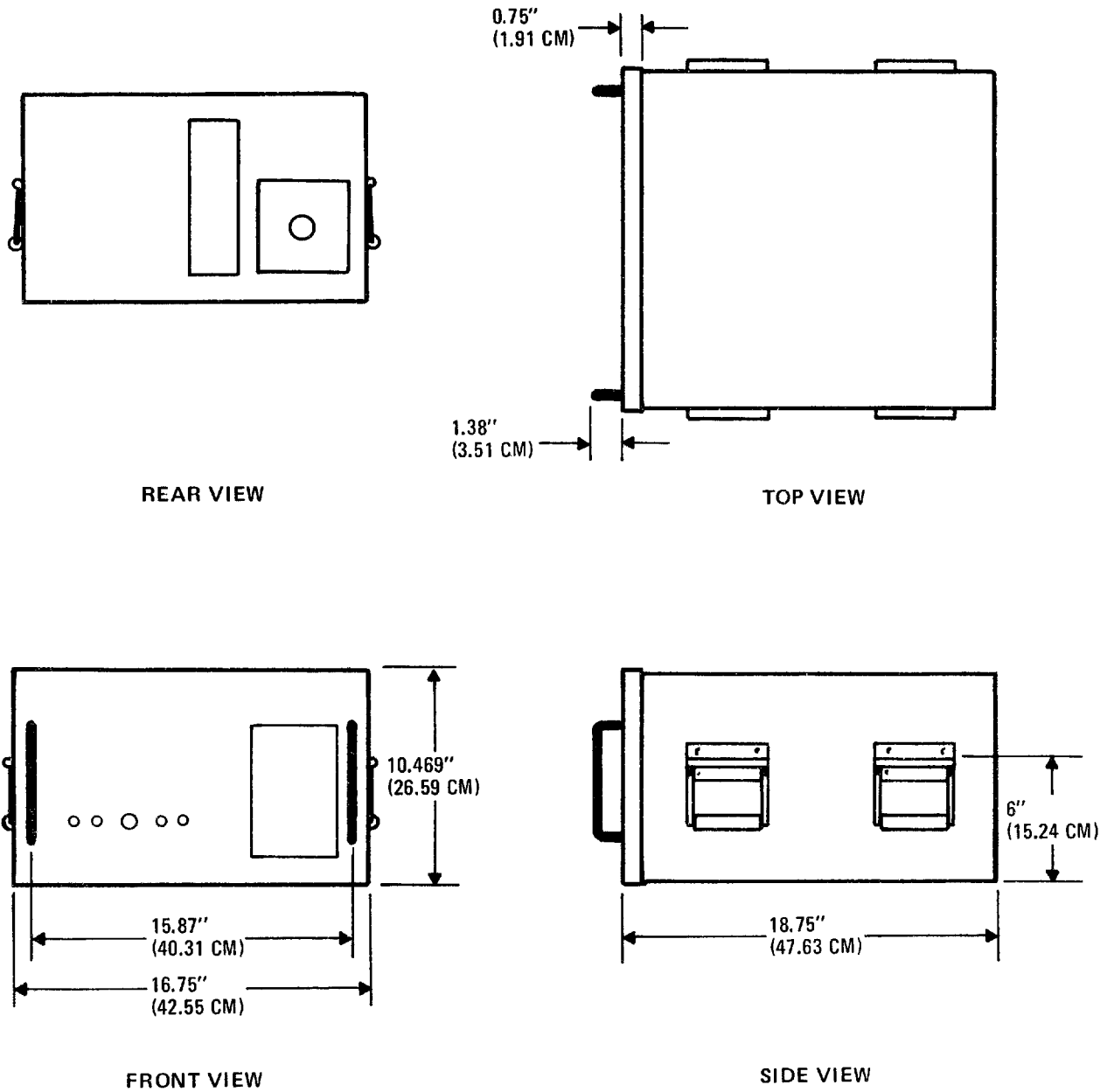

Figure 2-4. Dimensions

354-003

**Table 2-1. Interconnection Cabling Information**

J1 Power (LPA end) Mating connector 10087-0016		J1 Power (Power Supply end) Mating connector: 10087-0016
J1-A	Power-on Switch	J1-A
J1-B	High Voltage On	J1-B
J1-C	Spare	J1-C
J1-D	Spare	J1-D
J1-E	115 VAC Filament	J1-E
J1-F	115 VAC Filament	J1-F
J1-G	Ground	J1-G
J1-H	Power-on Return (Ground)	J1-H
J1-J	Ground	J1-J
J1-K	+13.5 Vdc	J1-K
J1-L	B+ Sample	J1-L
J1-M	B+ 3000 Volts*	J1-M
TB1 Input Power		
TB1-1	115/208/230 Vac (50, 60, 400 Hz) - Low	
TB1-2	Chassis Ground	
TB1-3	115/208/230 Vac (50, 60, 400 Hz) - High	
TB2 Input Pwr Strapping (Reference only)		
TB2-1	T1 (winding 1) - 130V tap	
TB2-2	T1 (winding 1) - 115V tap	
TB2-3	T1 (winding 1) - 105V tap	
TB2-4	T1 (winding 1) - 0V common	
TB2-5	T1 (winding 2) - 130V tap	
TB2-6	T1 (winding 2) - 115V tap	
TB2-7	T1 (winding 2) - 105V tap	
TB2-8	T1 (winding 2) - 0V common	
TB2-9	T2 (winding 1) - 115V tap	
TB2-10	T2 (winding 1) - 0V common	
TB2-11	T2 (winding 2) - 115V tap	
TB2-12	T2 (winding 2) - 0V common	
TB2-13	T2 (winding 2) - 93V tap	

\* Requires high-voltage wire, 20 KV rated minimum.

**CHAPTER 3**  
**PREPARATION FOR USE AND RESHIPMENT**

---

**Section I. PREPARATION FOR USE**

**3-1. INITIAL CONTROL SETTINGS.** The 1KW Power Supply does not have any external controls. All control of the 1KW Power Supply is effected from the front panel of the associated 1 KW LPA or from the front panel of the companion 100 Watt Transceiver.

**3-2. INITIAL POWER APPLICATION.** The POWER ENABLE switch on the 1 KW LPA front panel controls power to the 1KW Power Supply. Upon completion of the steps listed below, the operator will have confirmed that the 1KW Power

Supply is ready for the checkout test procedure given in paragraph 3-4.

**3-3. STEP-BY-STEP SEQUENCE FOR INITIAL POWER APPLICATION.** Follow the procedure in paragraph 3-3 of the on-equipment manual for the 1 KW LPA, T.O. 31R2-2URC-121.

**3-4. INITIAL CHECKOUT.** Follow the procedure in paragraphs 3-4 and 3-5 of the on-equipment manual for the 1 KW LPA, T.O. 31R2-2URC-121.

**Section II. PREPARATION FOR RESHIPMENT**

**3-5. PREPARATION FOR RESHIPMENT.**

Use original packing materials.

Power Supply from its mounting. Retain mounting hardware for future installation.

**3-6. STEP-BY-STEP DISASSEMBLY PROCEDURE.**

- a. Ensure that all power sources associated with the 1KW Power Supply are shut down.
- b. Disconnect all interface cables and grounding straps from the 1KW Power Supply.
- c. Replace plastic dust cover caps over 1KW Power Supply connectors.
- d. Unbolt mounting hardware and remove the 1KW

**3-7. STEP-BY-STEP PACKING AND CRATING PROCEDURE.**

- a. Refer to figure 2-1. Repackage all of the interface cables and mounting hardware associated with the 1KW Power Supply in the original (or an equivalent) container.
- b. Place the ancillary cables and mounting hardware into the container along with the 1KW Power Supply.
- c. Close and bind the container.

**CHAPTER 4****OPERATION**

---

**Section I. CONTROLS AND INDICATORS**

**4-1. INTRODUCTION.** The 1KW Power Supply has no external operating controls, and only one indicator. Its operation is automatically performed upon initiation of control signals from the associated 100 Watt Transceiver or 1 KW LPA. If there is any reason to suspect a problem in the 1KW Power Supply, refer to the 1 KW LPA on-equipment manual, T.O. 31R2-2URC-121, chapter 6, paragraph 6-7 and table 6-2, and initiate the BIT test sequence. Figure 4-1 shows the 1 KW Power Supply front panel.

**4-2. INDICATIONS OF NORMAL OPERATION.**

a. Power ON. When the 1KW Power Supply is

connected to the 1KW Linear Power Amplifier and to a 100 Watt Transceiver, the front panel POWER ON indicator will come on and the fan will run when power on is commanded from the 100 Watt Transceiver. This command is +13.5 Vdc from the 100 Watt Transceiver, through an ENABLE switch on the 1KW LPA front panel and through unit interlocks. There are two unit interlocks on the 1KW Power Supply, one on the cover and the other on the access panel covering the primary power strapping terminal board at the rear of the unit.

b. HV ON. High Voltage ON is also commanded from the 1KW LPA. The HV ON indicator is on the 1KW LPA.

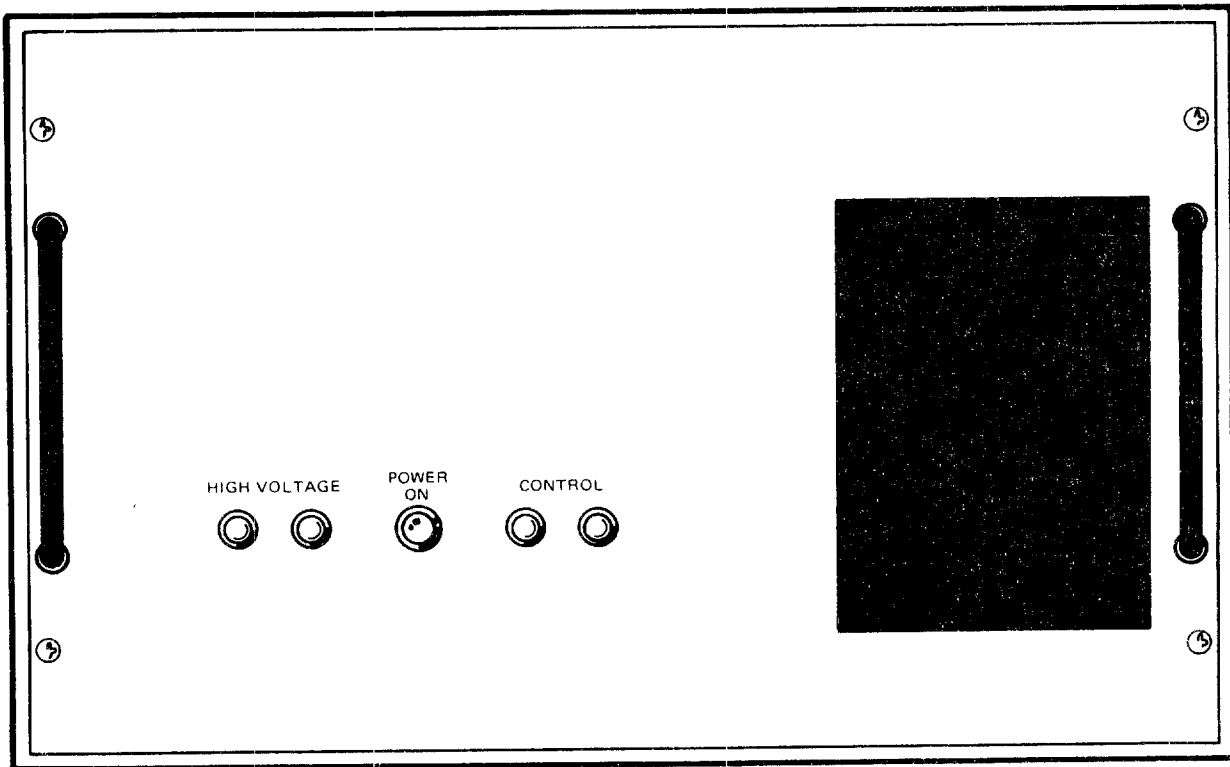

354-004

Figure 4-1. Operating Controls and Indicators

**Section II. OPERATING INSTRUCTIONS**

**4-3. INTRODUCTION.** Refer to chapter 4, section 2, of the 1 KW LPA On-Equipment Manual,

T.O. 31R2-2URC-121, for instructions that will initiate automatic operation of the 1KW Power Supply.





## CHAPTER 5

### THEORY OF OPERATION

**5-1. GENERAL DESCRIPTION.** The 1KW Power Supply is a 115/208/230 Vac, 50/60/400 Hz, single-phase power supply that produces three output voltages: +3000 Vdc power amplifier plate supply at up to 1 ampere; +13.5 Vdc at up to 8 amperes; and 115 Vac at up to 1 ampere. See the schematic diagram FO-1 in chapter 8 for the discussion that follows.

**5-2. PRIMARY POWER STRAPPING.** Primary power from the source terminates at TB1 on the rear of the unit. The source should be capable of delivering up to 4000 volt-amps.. This means that at 208 Vac, connections to TB1 should be capable of handling 20 amperes; at 230 Vac, 18 amperes; and at 115 Vac, 40 amperes. TB1 and TB2 have protective covers. The metal plate covering TB2 activates an interlock (S1) in the primary power control circuit. With this interlock open, primary power control relay K2 cannot be activated and the circuit from TB1 to TB2 cannot be completed.

**WARNING**

Always verify that primary power has been removed at the source before making any TB1 terminal board wiring changes.

Figure 2-2 gives strapping information for TB1 as a function of the normal input voltage.

**5.3 POWER ON CONTROL** With primary power present at TB1, the 13.5 Vdc supply can be energized by providing both 13.5 Vdc at J1-A and 13.5 Vdc return at J1-H. With both interlocks S1 and

S2 closed, relay K2 will be energized and complete the primary power circuit through terminal strip TB2 to low voltage transformer T2 (assuming CB1 and CB2 are closed).

**5.4 115 VAC FILAMENT SUPPLY.** Transformer T2 acts as an autotransformer supplying 115 Vac to connector pins J1-E and J1-F for use as filament voltage by the 1 KW LPA. Front panel lamp DS1 is also illuminated by this 115 Vac.

**5.5 13.5 VDC SUPPLY.** The 13.5 VDC Supply uses the center-tapped output of transformer T2 in a full-wave rectifier circuit to produce the 13.5 Vdc output. Capacitor C2 provides filtering and resistor R6 is the bleeder. The power supply cooling fan B1 is connected across this output and is activated when the 13.5 Vdc output is activated. This voltage will also be present as an enabling voltage at the HV ON contactor K1.

**5.6 HIGH VOLTAGE SUPPLY.** Primary power is applied to the high voltage transformer T1 through contactor K1 and terminal strip TB2. Contactor K1 is activated by a ground signal applied to connector pin J1-B. The high voltage secondary is connected in a full-wave bridge choke input filter configuration to provide the nominal +3000 Vdc high voltage output. Rectifiers CR1 through CR4 form the full-wave bridge circuit, while choke L1 and capacitor C1 form the filter network. Resistors R1 through R3 provide both a bleeder action and a divider circuit to supply a B+ sample through resistor R4 and capacitor C3 to the bias circuit of the power amplifier tube in the 1KW LPA. Switch S2 is a mechanically operated crowbar that shorts the +3000 Vdc output to ground as a safety measure when the cover is removed.



## CHAPTER 6

### MAINTENANCE

---

**WARNING**

Dangerous voltages exist in this radio equipment. Remove power and wait 30 seconds for dangerous voltages to bleed off before removing any covers.

**6-1. GENERAL.** There are no adjustments in the 1KW Power Supply. Field maintenance for the 1KW Power Supply is limited to replacing the components identified in Chapter 7, Illustrated Parts Breakdown. Refer also to the troubleshooting procedures in Chapter 6 of the On-equipment Manual for the 1KW Linear Power Amplifier (T.O. 31R2-2URC-121).

**6-2. PERIODIC MAINTENANCE.** The 1KW Power Supply requires only a limited amount of periodic maintenance. The following actions are recommended at the intervals listed. During any of the specific procedures listed, take note of any unusual equipment conditions which may indicate degrading or degraded performance, and make the necessary corrections.

#### NOTE

**Field and Organizational Maintenance of the modules and circuit card assemblies is limited to the removal, replacement, and alignments given in Chapter 6.**

#### Tool List

Screwdriver:

3/16-inch flat blade (4 inches long)

a. Clean Air Filter. Clean the equipment air filter every 14 days for 24-hour continuous equipment operation, or sooner if filter is noticeably soiled. Use soap and water; dry thoroughly before replacing.

b. Dust Accumulation. At 28-day intervals, check the interior of the power supply for dust accumulation. Remove any excessive dust accumulation as required.



## CHAPTER 7

### ILLUSTRATED PARTS BREAKDOWN

#### Section 1. INTRODUCTION

**7-1. PURPOSE.** This chapter lists, illustrates, and describes the detail parts for the 1 KW Power Supply. Its purpose is for the identification, requisitioning, and issuance of parts at the organizational (on-equipment) level.

**7-2. SCOPE.** Only parts that are coded as replaceable at the organizational level are listed in this chapter. These include the major detail parts. Mounting hardware is listed only if it is used to attach a replaceable detail part and only if it is not held captive to the part. In general, the parts installed at the time the 1 KW Power Supply was manufactured are listed and identified in this chapter. When a part (including vendor items), which is different from the original, was installed during the manufacture of later items, series, or blocks, all parts are listed (and "Usable-On" coded). However, when the original part does not have continued application (no spares of the original were procured or such spares are no longer authorized for replacement), only the preferred part is listed. Also, when a part was installed during modification, and the original does not have continued application, only the preferred item is listed. Interchangeable and substitute parts, subsequently authorized by the Government, are not listed in this chapter; such items are identified by information available through the Interchangeable and Substitute (I & S) Data Systems. Refer to T.O. 00-25-184. When a standard size part

can be replaced with an oversize or undersize part, the latter parts, showing sizes, are also listed. Repair Parts Kits and Quick Change Units are listed when they are available for replacement.

**7-3. CHAPTER ORGANIZATION.** This chapter is divided into two sections. Section I, INTRODUCTION, explains the purpose, scope, and organization of the chapter. Section II, MAINTENANCE PARTS LIST, consists of illustrations, in which the detail parts of the 1 KW Power Supply are identified by numbers (called index numbers), followed by lists which contain parts numbers, descriptions, and other relevant data for the items identified on the illustrations.

**7-4. SOURCE, MAINTENANCE, AND RECOVERABILITY (SMR) CODES.** This chapter contains Air Force Peculiar In-Being Source and Repair Codes only. Definitions of these SMR codes, as well as detailed coding criteria and transposition matrices for each coding method, may be obtained from T.O. 00-25-195. Refer to page 7-3.

**7.5. FEDERAL SUPPLY CODES FOR MANUFACTURERS (FSCM).** The codes used in this chapter are as follows. The first list is in numerical order by FSCM; the second is in alphabetical order by manufacturer name.

**T.O. 35C1-2-892-1**

<b>FSCM</b>	<b>NAME AND ADDRESS</b>	<b>77342</b>	<b>AMF Incorporated Potter and Brumfield Division 200 Richland Creek Drive Princeton, Indiana 47671</b>	<b>Loctite Corporation 705 North Mountain Road Newington, Connecticut 06111</b>	<b>05972</b>
00758	Neilson Products Company Lake Elmo, Minnesota				
05972	Loctite Corporation 705 North Mountain Road Newington, Connecticut 06111	81349	Military Specification Code	Magna Division Vermont American Corporation 1001 West Park Road Elizabethtown, Kentucky 42701	11195
06540	Mite Corporation Amatom Electronic Hardware Division 446 Blake Street New Haven, Connecticut 06515	82877	Rotron Incorporated Custom Division 7 Hasbrouck Lane Woodstock, New York 12498	Mite Corporation Amatom Electronic Hardware Division 446 Blake Street New Haven, Connecticut 06515	06540
09023	Cornell-Dubilier Electronics 118 East Jones Street Fuquay-Varina, North Carolina 27526	88325	Aircraft Accessories Corporation Burbank, California	Neilson Products Company Lake Elmo, Minnesota	00758
09166	Stone City Products Inc. 1206 7th Street P.O. Box 369 Bedford, Indiana 47421	96906	Military Specification Code	Rotron Incorporated Custom Division 7 Hasbrouck Lane Woodstock, New York 12498	82877
09166	Stone City Products Inc. 1206 7th Street P.O. Box 369 Bedford, Indiana 47421	97520	Basler Electric Company Route 143 P.O. Box 269 Highland, Illinois 62249		
10026	CSI Capacitors A Division of CSI Technologies Incorporated Del Dios Highway P.O. Box 2052 Escondido, California 92025	<b>NAME AND ADDRESS</b>	<b>FSCM</b>	Sprague Electric Company 87 Marshall Street North Adams, Massachusetts 01247	56289
11195	Magna Division Vermont American Corporation 1001 West Park Road Elizabethtown, Kentucky 42701	Aircraft Accessories Corporation Burbank, California	88325	Stone City Products Inc. 1206 7th Street P.O. Box 369 Bedford, Indiana 47421	09166
12697	Clarostat Manufacturing Company Incorporated Lower Washington Street Dover, New Hampshire 03820	AMF Incorporated Potter and Brumfield Division 200 Richland Creek Drive Princeton, Indiana 47671	77342	Thomas and Betts Corporation Highway 218 South Iowa City, Iowa 52240	59730
14304	Harris Corporation RF Communications Group 1680 University Avenue Rochester, New York 14610	Basler Electric Company Route 143 P.O. Box 269 Highland, Illinois 62249	97520	Varo Semiconductor Incorporated Subsidiary of Varo Incorporated 1000 North Shiloh Road P.O. Box 40676 Garland, Texas 75040	62703
51144	IDI Electric Canada Limited 33 Fuller Road Box 159 Ajax, Ontario, Canada L1S 2E1	Carborundum Corporation The Electrical Products Division Global Plant 3425 Hyde Park Blvd. P.O. Box 339 Niagara Falls, New York 14302	72819		
56289	Sprague Electric Company 87 Marshall Street North Adams, Massachusetts 02147	Clarostat Manufacturing Company Incorporated Lower Washington Street Dover, New Hampshire 03820	12697		
59730	Thomas and Betts Corporation Highway 218 South Iowa City, Iowa 52240	Cornell-Dubilier Electronics 118 East Jones Street Fuquay-Varina, North Carolina 27526	09023		
59993	International Rectifier Semiconductor Division 233 Kansas Street El Segundo, California 90245	CSI Capacitors A Division of CSI Technologies Incorporated Del Dios Highway P.O. Box 2052 Escondido, California 92025	10026		
62703	Varo Semiconductor Incorporated Subsidiary of Varo Incorporated 1000 North Shiloh Road P.O. Box 40676 Garland, Texas 75040	DZUS Fastener Company Inc. 425 Union Blvd. West Islip, New York 11795	72794		
72794	DZUS Fastener Company Inc. 425 Union Blvd. West Islip, New York 11795	Harris Corporation RF Communications Group 1680 University Avenue Rochester, New York 14610	14304		
72819	Carborundum Company The Electrical Products Division Global Plant 3425 Hyde Park Blvd. P.O. Box 339 Niagara Falls, New York 14302	IDI Electric Canada Limited 33 Fuller Road Box 159 Ajax, Ontario, Canada L1S 2E1	51144		
		International Rectifier Semiconductor Division 233 Kansas Street El Segundo, California 90245	59993		

Note: Field and organizational maintenance of the modules and circuit card assemblies is limited only to the removals, replacements, and alignments given in chapter 6.

JOINT MILITARY SERVICES UNIFORM SMR CODING MATRIX T.O. 00-25-195

SOURCE		USE		MAINTENANCE REPAIR		RECOVERABILITY		ERRC CODE	
1st Position	2nd Position	3rd Position	4th Position	5th Position	6th Position				
P	A Stocked	O Remove/Replace at Organizational Level	Z No Repair	Z Nonreparable Condemn at 3rd Position Level	N Nonrecoverable XB3 Condemn at Any Level				
	B Insurance								
	C Deteriorative								
	E Support Equipment, Stocked								
	F Support Equipment, Nonstocked								
	G Sustained Life Support								
K	F Intermediate Kit	F Remove/Replace at Intermediate Level	O Repair at Organizational	F Repairable Condemn at Intermediate	C Recoverable XD1 (SCARS) Condemn at Depot				
	D Depot Kit								
	B In Both Kits								
M	O Organization	D Remove/Replace at Depot Level	D Limited Repair at O or F Level	D Repairable Condemn at Depot	S Nonexpendable Support Equipment, Depot ND2				
	F Intermediate								
	D Depot								
A	O Organization	D Remove/Replace at Depot Level	D Limited Repair at O or F Level	D Repairable Condemn at Depot	S Nonexpendable Support Equipment, Depot ND2				
	F Intermediate								
	D Depot								
X	A Requisition NHA	D Remove/Replace at Depot Level	D Limited Repair at O or F Level	D Repairable Condemn at Depot	S Nonexpendable Support Equipment, Depot ND2				
	B Reclamation from IM								
	C Mfg Drawings								



Section II. MAINTENANCE PARTS LIST

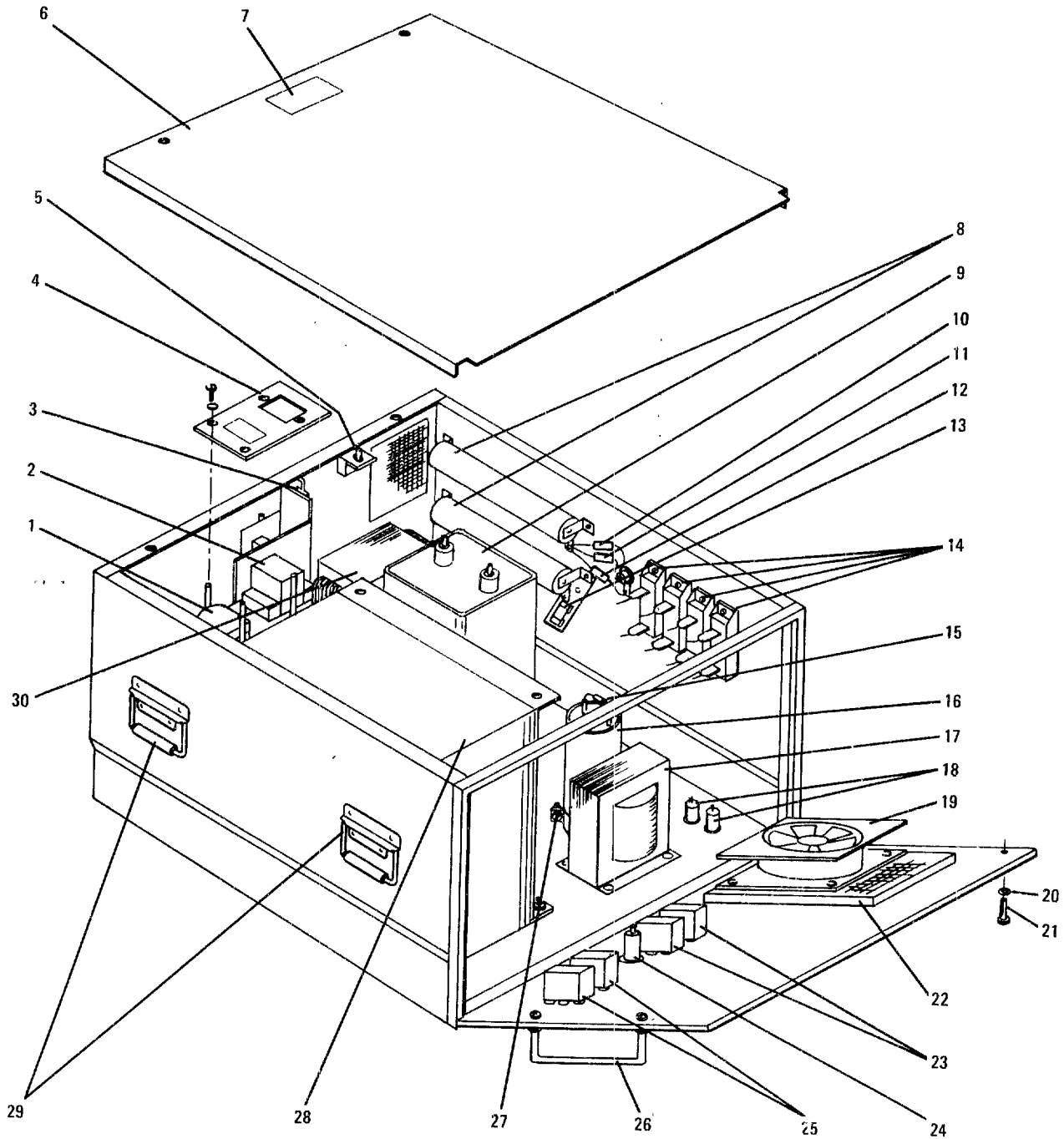

354-008

Figure 7-1. 1 KW Power Supply, PP-7913/URC

## ILLUSTRATED PARTS BREAKDOWN

Fig. & Index No.	Part No.	FSCM	Description 1 2 3 4 5 6 7	Units Per Assy	Usable on Code	SMR Code
7-1-	10087-5000	14304	Power Supply			PAODD
1	W389CX-7	11195	. Relay	1		PAOZZ
	H-6768	96906	. Nut, Keps (AP)	20		XB
	MS15795-806	96906	. Washer, Flat (AP)	9		PAOZZ
2	P25P44D32P112	77342	. Relay	1		PAOZZ
	MS51958-67	96906	. Screw, Machine (AP)	2		PAOZZ
	MS15795-807	96906	. Washer, Flat (AP)	6		PAOZZ
3	MS16106-4	96906	. Switch	2		PAOZZ
	MS51958-13	96906	. Screw, Machine (AP)	4		PAOZZ
	MS35338-135	96906	. Washer, Lock (AP)	6		PAOZZ
4	10087-5104	14304	. Cover, Relay	1		XB
	MS51957-29	96906	. Screw, Machine (AP)	4		PAOZZ
	MS35338-136	96906	. Washer, Lock (AP)	5		PAOZZ
	MS15795-805	96906	. Washer, Flat (AP)	11		PAOZZ
	MP-0745	14304	. Label, Warning	2		MDO
5	10087-5224	14304	. Switch Assy	1		XB
	MS51957-14	96906	. Screw, Machine (AP)	2		PAOZZ
	MS35338-135	96906	. Washer, Lock (AP)	Ref.		PAOZZ
	MS15795-803	96906	. Washer, Flat (AP)	2		PAOZZ
6	10087-3104	14304	. Cover, Power Supply	1		XB
	AJ4-35-SS	72794	. Stud, Retainer (AP)	2		XB
	SR-4-SS	72794	. Retainer (AP)	2		XB
7	10087-5010	14304	. Label, Danger	1		MDO
8	RW38V271	81349	. Resistor	2		PAOZZ
	MS51957-28	96906	. Screw, Machine (AP)	1		PAOZZ
	MS35338-136	96906	. Washer, Lock (AP)	Ref.		PAOZZ
	MS51957-30	96906	. Screw, Machine (AP)	5		PAOZZ
	H-6768	96906	. Nut, Keps (AP)	Ref.		XB
9	4N322TNP	10026	. Capacitor, Fxd, Paper	1		PAOZZ
	1020F251	09166	. Bracket, Mtg., Cap (AP)	2		XB
	TC-105A	59730	. Base (AP)	1		XB
	H-6768	96906	. Nut, Keps (AP)	Ref.		XB
	MP-0745	14304	. Label, Warning	Ref.		MDO
10	M39003/01-3100	81349	. Capacitor, Fxd.Elett.	1		PAOZZ
11	RCR32G392JS	81349	. Resistor, Fixed	1		PAOZZ
12	RWR74S1621FS	81349	. Resistor, Fixed	1		PAOZZ
13	885SP220L	72819	. Resistor, Fixed	1		PAOZZ
14	VC80	62703	. Semicond Device, DIO	4		PAOZZ
	MS51957-31	96906	. Screw, Machine (AP)	8		PAOZZ
	MS15795-806	96906	. Washer, Flat (AP)	Ref.		PAOZZ
	H-6768	96906	. Nut, Keps (AP)	Ref.		XB
15	RCR32G102JS	81349	. Resistor, Fixed	1		PAOZZ
16	3120EE383U025AM	56289	. Cap, Fxd, Elctlt	1		PAOZZ
	MS51957-30	96906	. Screw, Machine (AP)	Ref.		PAOZZ
	MS15795-805	96906	. Washer, Flat (AP)	Ref.		PAOZZ
17	10087-5110	14304	. Transformer, RF	1		PAOZZ
	10043-0039	14304	. Resistor, Network	2		PAOZZ
	MS15795-807	96906	. Washer, Flat (AP)	Ref.		PAOZZ
	H-6767	96906	. Nut, Keps (AP)	4		XB
18	70HFR20	59993	. Semicond Device, DIO	2		PAOZZ

**ILLUSTRATED PARTS BREAKDOWN  
(Continued)**

Fig. & Index No.	Part No.	FSCM	Description							Units Per Assy	Usable on Code	SMR Code
			1	2	3	4	5	6	7			
19	028868	82877	.	Fan						1		PAOZZ
	MS15795-805	96906	.	Washer, Flat (AP)						Ref.		PAOZZ
	H-6768	96906	.	Nut, Keps (AP)						Ref.		XB
20	10087-2011	14304	.	Washer, Flat						4		PAOZZ
21	10087-2012	14304	.	Screw, Machine						4		PAOZZ
22	10087-2010	14304	.	Filter, Air						1		PAOZZ
23	W58XB1A6A-2	77342	.	Circuit Brkr						2		PAOZZ
24	1050QA3	51144	.	Lamp						1		PAOZZ
25	W58XB1A6A-20	77342	.	Circuit Brkr						2		PAOZZ
26	10353-B-1032-6A	06540	.	Handle, Bow						2		XB
	MS24693-C273	96906	.	Screw, Machine (AP)						4		PAOZZ
	16022-A2	06540	.	Bushing (AP)						4		XB
27	34775-2	09023	.	Bracket, Mtg. Cap. (AP)						1		XB
	MS51958-64	96906	.	Screw, Machine (AP)						1		PAOZZ
28	H-6766	96906	.	Nut, Keps (AP)						5		XB
	BE1608001	97520	.	Transformer						1		PAOLD
	MS51957-83	96906	.	Screw, Machine (AP)						4		PAOZZ
29	MS35338-139	96906	.	Washer, Lock (AP)						4		PAOZZ
	MS15795-811	96906	.	Washer, Flat (AP)						4		PAOZZ
	985	00758	.	Handle, Lift						4		XB
	MS51957-44	96906	.	Screw Machine (AP)						16		PAOZZ
	H-6767	96906	.	Nut, Keps (AP)						Ref.		XB
30	P6527	88325	.	Transformer						1		PAOZZ
	MS15795-808	96906	.	Washer, Flat (AP)						4		PAOZZ
	H-6766	96906	.	Nut, Keps (AP)						Ref.		XB

**REFERENCE DESIGNATOR INDEX**

Reference Designator	Figure & Index No.	Part Number	Reference Designator	Figure & Index No.	Part Number
B1	7-1-1	028868	L1	7-1-1	P6527
C1	7-1-1	4N322TNP	R1, R2	7-1-1	RW38V271
C2	7-1-1	3120EE383U025AM	R3	7-1-1	RWR74S1621FS
C3	7-1-1	M39003/01-3100	R4	7-1-1	RCR32G392JS
CB1, CB2	7-1-1	W58XB1A6A-2	R5	7-1-1	885SP220L
CB3, CB4	7-1-1	W58XB1A6A-20	R6	7-1-1	RCR32G102JS
CR1-CR4	7-1-1	VC80	RV1, RV2	7-1-1	10043-0039
CR5, CR6	7-1-1	70HFR20	S1, S3	7-1-1	MS16106-4
DS1	7-1-1	1050QA3	S2	7-1-1	10087-5224
K1	7-1-1	P25P44D32P112	T1	7-1-1	BE1608001
K2	7-1-1	W389CX-7	T2	7-1-1	10087-5110

CHAPTER 8  
FOLDOUT DRAWINGS

---

LIST OF 1KW POWER SUPPLY FOLDOUT DRAWINGS

FO-1 1 KW Power Supply Schematic Diagram



NOTE: UNLESS OTHERWISE SPECIFIED:

1. PARTIAL REFERENCE DESIGNATIONS ARE SHOWN FOR DETAIL PARTS. PREFIX THESE WITH UNIT NO. AND/OR ASSEMBLY DESIGNATIONS SHOWN ON DRAWING TO OBTAIN COMPLETE DESIGNATIONS.
2. ALL RESISTOR VALUES ARE IN OHMS, 1/4W, ±5%.
3. ALL CAPACITOR VALUES ARE IN MICROFARADS (UF).
4. ALL INDUCTANCE VALUES ARE IN MILLIHENRIES (MH).
5. VENDOR PART NO. CALLOUTS ARE FOR REFERENCE ONLY. COMPONENTS ARE SUPPLIED PER PART NO. IN PARTS LIST.
6. DC RESISTANCES OF INDUCTIVE ELEMENTS (CHOKES, COILS, MOTOR WINDINGS, ETC.) ARE LESS THAN 1 OHM.
7. PANEL DECALS ARE INDICATED BY BOLD TYPE IN A BOLD BOX, E.G., **ON/OFF**.
8. ALL RELAYS ARE SHOWN IN THE DE-ENERGIZED STATE.
9. CONNECTIONS SHOWN ARE FOR 230 VAC PRIMARY LINE VOLTAGE. FOR OTHER VOLTAGES, CONNECT WIRES AND JUMPERS AT TB2 AS PER THE FOLLOWING TABLE:

VOLTAGE	#14 AWG	JUMP1	JUMP2	JUMP3	JUMP4
115	3	2-6	4-8	9-11	10-12
208	2	4-7	NONE	10-13	NONE
230	3	4-6	NONE	10-11	NONE

HIGHEST REFERENCE DESIGNATION				
B1	C3	CB4	CR6	DS1
J1	K2	LI	R6	RV2
REFERENCE DESIGNATIONS NOT USED				
E5	P3			

HIGHEST REFERENCE DESIGNATION		
S3	T2	TB2
REFERENCE DESIGNATIONS NOT USED		

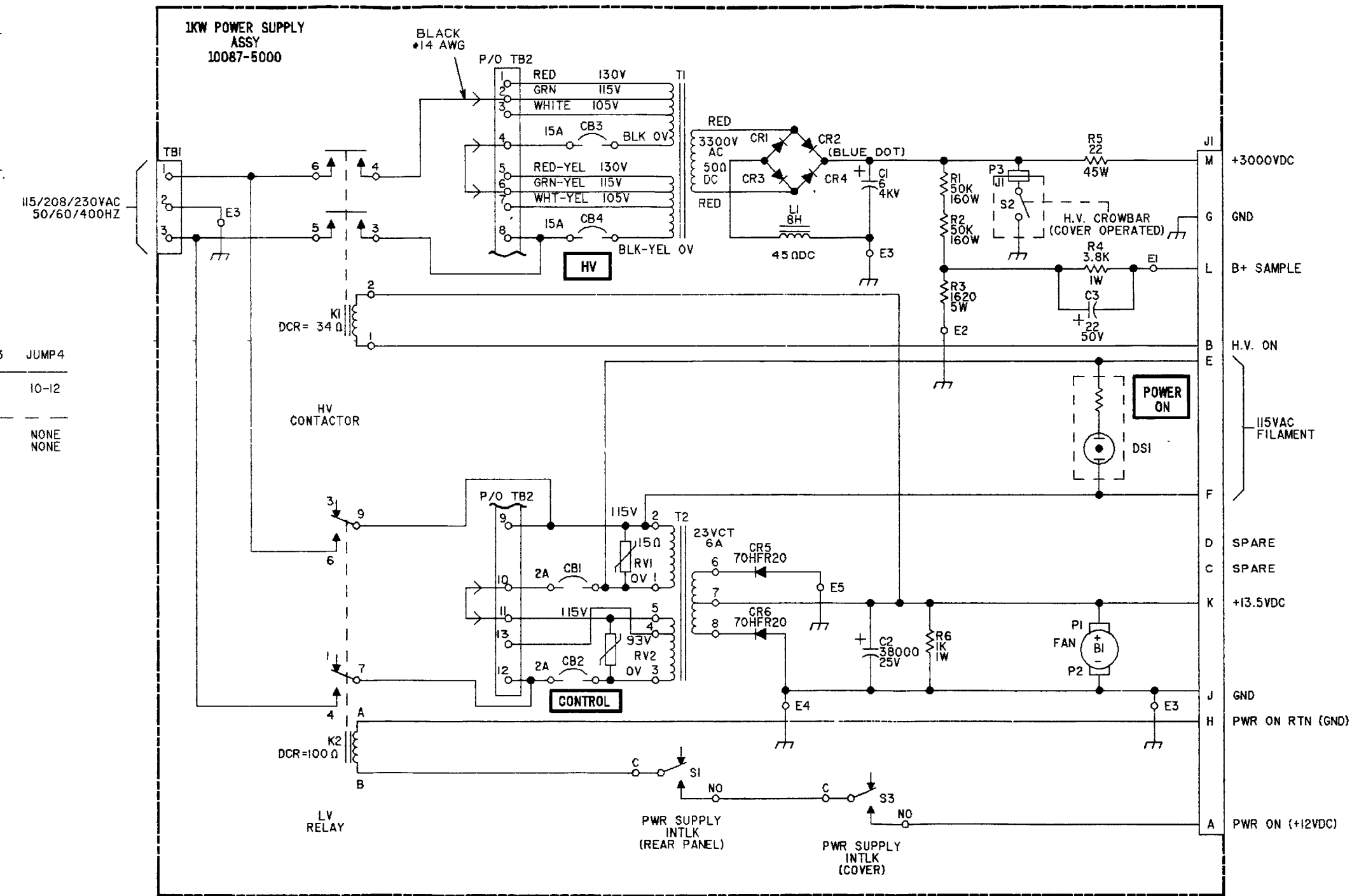

Figure FO-1. 1 KW Power Supply Schematic Diagram  
FP-1/(FP-2 Blank)

